

225 SOLAR PANEL

EXCEPTIONAL EFFICIENCY AND PERFORMANCE

BENEFITS

Highest Efficiency

Panel efficiency of 18.1% is the highest commercially available for residential applications.

More Power

SunPower 225 delivers up to 50% more power per unit area than conventional solar panels.

Attractive Design

Unique all back-contact solar cells and optimized panel design eliminate harsh reflection from front-side metal contacts.

Reliable and Robust Design

Proven materials, tempered front glass, and a sturdy anodized frame allow panel to operate reliably in multiple mounting configurations.

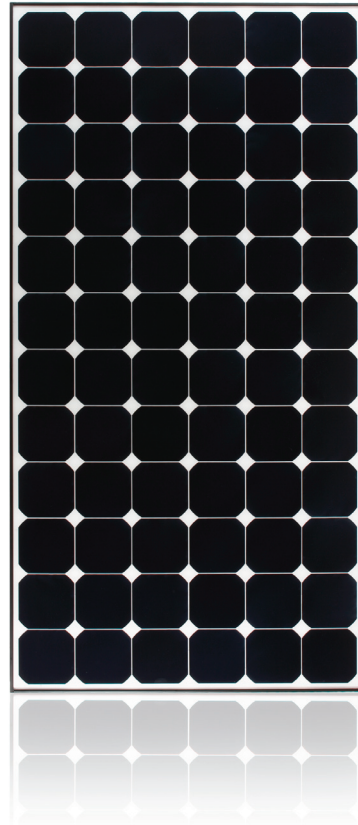

The SunPower 225 Solar Panel provides today's highest efficiency and performance for residential use. Utilizing 72 next generation SunPower all back-contact solar cells and an optimized panel design, the SunPower 225 elegantly delivers an unprecedented total panel conversion efficiency of 18.1%. The panel's reduced voltage-temperature coefficient and exceptional low-light performance attributes provide outstanding energy delivery per peak power watt.

SunPower's High Efficiency Advantage - up to 50% More Power

Comparable systems covering 25 m ² / 270 ft ²		
	Conventional	SunPower
Watts / Panel	165	225
Efficiency	12.0%	18.1%
kWs	3.0	4.5

Electrical Data

Measured at Standard Test Conditions (STC): irradiance of 1000/m², air mass 1.5g, and cell temperature 25° C

Peak Power (+/-3%)	Pmax	225 W
Rated Voltage	Vmp	41.0 V
Rated Current	Imp	5.49 A
Open Circuit Voltage	Voc	48.5 V
Short Circuit Current	Isc	5.87 A
Maximum System Voltage	IEC	1000 V
Temperature Coefficients		
	Power	-0.38% /°C
	Voltage (Voc)	-132.5 mV/°C
	Current (Isc)	3.5 mA/°C
Series Fuse Rating		20 A
Peak Power per Unit Area		181 W/m ²

Mechanical Data

Solar Cells	72 SunPower all back-contact monocrystalline
Front Glass	3.2 mm (1/8 in) tempered
Junction Box	IP-65 rated with 3 bypass diodes
Output Cables	900 mm length cable / Multi-Contact connectors
Frame	Anodized aluminum alloy type 6063
Weight	15 kg, 33 lbs

IV Curve

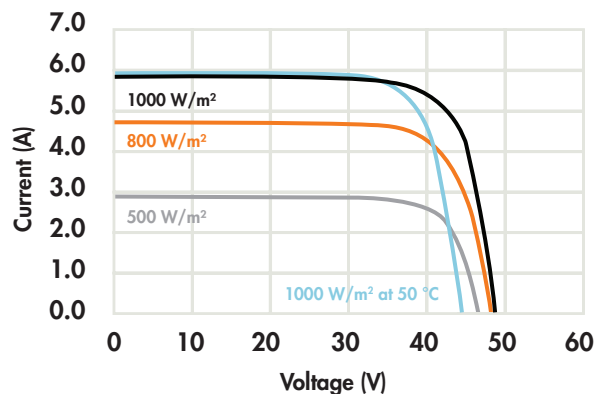

Current/voltage characteristics with dependence on irradiance and module temperature.

Tested Operating Conditions

Temperature	-40° C to +85° C (-40°F to +185°F)
Max load	240 kg/m ² (2400 Pascals) front and back
Impact Resistance	Hail - 25mm (1 in) at 23 m/s (52 mph)

Warranty and Certifications

Warranty	25 year limited power warranty 10 year limited product warranty
Certifications	IEC 61215 , Safety tested IEC 61730

Dimensions

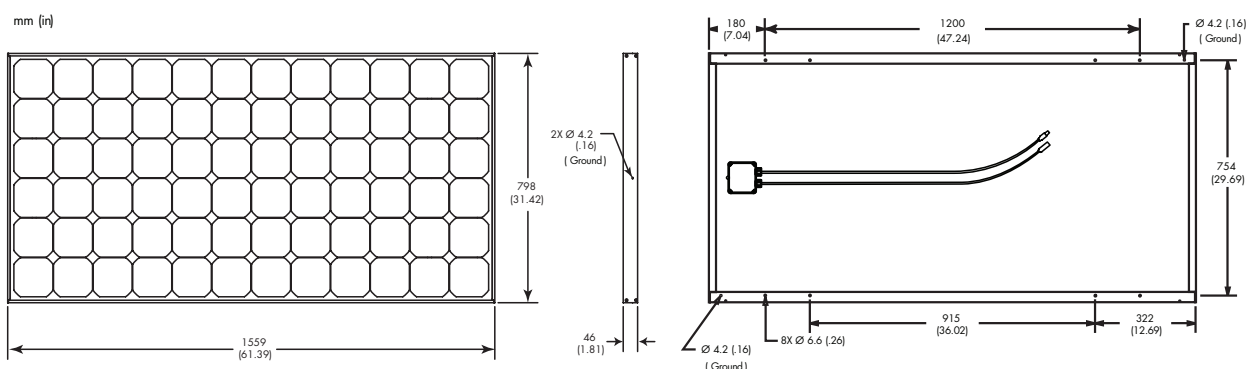

CAUTION: READ SAFETY AND INSTALLATION INSTRUCTIONS BEFORE USING THE PRODUCT. Go to www.sunpowercorp.com/panels for details

About SunPower

SunPower designs, manufactures and delivers high-performance solar electric technology worldwide. Our high-efficiency solar cells generate up to 50 percent more power than conventional solar cells. Our high-performance solar panels, roof tiles and trackers deliver significantly more energy than competing systems.